Structure of Hardened Concrete

- Concrete has a highly heterogeneous and complex structure.
 - Three components of concrete structure— the **hydrated cement paste**, the **aggregate**, and the **interfacial transition zone** between the cement paste and the aggregate— are described and discussed from the standpoint of selected characteristics of concrete, such as strength, dimensional stability.
-

Definition – in this field

- **Structure:** the type, amount, size, shape, and distributions (of components or inclusions) in a solid constitute.
 - **Macrostructure:** the gross structure, visible to human eye (200 μm)
 - **Microstructure:** the microscopically magnified portion of a macrostructure
10⁵ times (roughly <100nm)
-

Significance

- Progress in the field of materials has resulted primarily from the recognition of the principals that the properties of a material originate from its internal structure.
 - The structure-property relationship-not yet developed, however, an understanding of some of the element of the concrete structure is essential before we discuss the factors influencing the important engineering properties of concrete- strength, elasticity, shrinkage, creep, cracking, durability
-

Complexities

Fig2.1

- At the macroscopic level, concrete is considered to be 2 phase material, consisting of aggregate particles dispersed in a matrix of the cement paste. 2 phases of the structure are neither homogeneously distributed with respect to each other nor are they themselves homogeneous
-

Complexities Cont.

- 1. In the presence of aggregate, the structure of hcp in the vicinity of large aggregate particles is usually very different from the structure of bulk paste or mortar in the system.: **third phase transition zone.**
 - 2. each of the three phase is itself multiphase in nature.
 - several materials and voids, microcracks
 - 3. **change with time**
-

Structure of the aggregate phase 1 2 • 4

The aggregate phase is predominantly responsible for the **unit weight, elastic modulus and dimensional stability** of concrete. These properties of concrete are determined by **the physical rather than chemical characteristics** of the aggregate structure.

-
- Crushed rocks have a rough texture, flat or elongated particles
 - the larger the size of the aggregate, the greater the tendency for water films to accumulate next to the aggregate surface, thus weakening the cement paste–aggregate transition zone.: **internal bleeding**
 - **Fig.2-4**
 - Minerals: quartz(石英), feldspar(長石)
-

Structure of hardened cement paste

- Anhydrous portland cement is a gray powder that consists of angular particles typically in the size range 1 to 50 μ m.
 - When portland cement is dispersed in water, the calcium sulfate and the high temperature compounds of calcium tend to go into solution.
 - C_3S , C_2S , C_3A , C_4AF
-

within a first few minutes of cement hydration: the needle shaped crystals of a calcium sulfoaluminate hydrate called **ettringite** make their appearance.

a few hours later: large prismatic crystals of calcium hydroxide and very small fibrous crystals of calcium silicate hydrates begin to fill the empty spaces

After some days: **ettringite may become unstable and decompose to form the monosulfate hydrate**

In solid: microstructural inhomogeneities can lead to serious effects on strength and other related mechanical properties because these properties are controlled by the microstructural extremes. (voids, weak parts, edges etc.)

(Some other properties are average of the constituent materials.)

Calcium silicate hydrate

- abbreviated C-S-H gel makes up 50 to 60% of the volume of solids
- not a well defined compound C/S varies between 1.5 to 2.0 (1.5 : $C_3S_2H_4$)
- from poorly crystalline fibers to reticular network
- referred to as C-S-H gel or tobermorite gel
- (W/C ratio has not so much influence on the chemical components, but on the porosity.)

Calcium hydroxide

- Calcium hydroxide constitute **20 to 25%**
- is a compound with a definite stoichiometry Ca(OH)_2
- it tends to form large crystals with a distinctive hexagonal-prism morphology.
- compared with C-S-H, the strength contributing potential of calcium hydrate due to **Van-der-waals forces** is limited as a result of a considerably lower surface area
- has **an adverse effect on chemical durability to acidic solutions because of the higher solubility of calcium hydroxide than C-S-H.**

Calcium sulfoaluminate

- this compounds occupy **15 to 20%**:minor role in the structure-property relationships
 - makes the concrete vulnerable to sulfate attack
 - Ettringite and mono-sulfate
 - **(against sulfate attack: less mono-sulfate after hardened.)**
-

Unhydrated clinker grains

- some unhydrated clinker grains may be found in the microstructure of hcp, even long after hydration.
-
- **Voids in hcp Fig.2-7**



Interlayer space in C-S-H

- Powers determined that it accounts for 28% porosity in solid C-S-H
 - Suggested that the space may vary from 5 to 25 Å.
 - This void size is **too small to have an adverse affect on the strength and permeability of the hcp.**
 - however, water in these small voids can be held by hydrogen bonding, and **its removal** under certain condition **may contribute to drying shrinkage and creep.**
-

Capillary voids

- The average bulk density of the hydration products is considerably lower than the density of anhydrous portland cement; it is estimated that 1cm³ of cement, on complete hydration, requires about 2cm² of space to accommodate the products of hydration. $w/c=1/3.14=32\%$
- The capillary voids may range from 10 to 50nm and more.
- larger than 50nm, referred to as macropores are assumed to be detrimental to strength and permeability
- while voids smaller than 50nm, referred to as micro-pores are assumed to be more important to drying shrinkage and creep.

Air voids

- Whereas the capillary voids are irregular in shape, the air voids are generally spherical.
 - Entrapped air voids may be as large as 3mm :
 - Entrained air voids usually 50 to 200micro m.
 - capable of adversely affecting its strength and impermeability
-

Water in hcp

- The classification of water into several types is based on the degree of difficulty or ease with which it can be removed from hcp.
 - The dividing line between the different water is not rigid
 - 簡単に取りれるものから順番に
-

Capillary water

- **Larger than 50nm**, which may be considered as free water because its removal does not cause any volume change
 - **Smaller than 50nm**, the water held by capillary tension in small capillaries which on removal may cause shrinkage of the system
-

Adsorbed water

- Close to the solid surface
 - Under the influence of attractive forces, water molecules are physically adsorbed onto the surface of solids in the hcp.
 - Up to 6 molecule layers of water(15A) can be physically held by hydrogen bonding.
 - A major portion of the adsorbed water can be lost by drying the hcp to 30% relative humidity.
 - Responsible for the shrinkage of the hcp on drying.
-

Interlayer water

- associated with the C-S-H structure:
monomolecular water layer
 - between the layers of C-S-H
 - is strongly held by hydrogen bonding
-

Chemically combined water

- An integral part of the structure of various cement hydration products
 - This water is not lost on drying
-

Structure Property relationships in hydrated cement paste

- The engineering properties are influenced not only by the proportions but also **by the properties of hcp.-microstructural features**
-

Strength -1

- It should be noted that the principle source of strength in the solid products of the hcp is the existence of the **van der Waals forces of attraction**.
 - The small **crystals of C-S-H** possess enormous **surface areas** and adhesive capability tend to adhere strongly not only to each other, but also to **low surface area solids** such as calcium hydroxide, anhydrous clinker grains, and fine and coarse aggregate particles.
-

Strength -2

- There is an inverse relationship between porosity and strength
 - In the hcp, the interfacial space within the CSH structure and the small voids cannot be considered detrimental to strength.
 - Two illustrations of the hydration progressive reduction in the capillary porosity are shown in Fig.2-10.
-

Strength-3

- Assuming 1cm^3 cement produces 2cm^3 of the hydration product. $W/C=1/3.14= 0.32$
- In case B, after complete hydration, all the paste would contain the same quantity of the solid hydration product,
- Therefore, the paste with the greater total space would end up with a correspondingly larger volume of capillary voids.
- It is possible to calculate the effect of increasing the W/C , first on porosity, and subsequently to the strength, by using Powers's formula
- * $S=kx^3$
- X: solid to space ratio

Dimensional stability-1

- Saturated hcp is not dimensionally stable.
 - when exposed to environmental humidity, the material will begin to lose water and shrink.
 - As soon as the RH drops below 100%, the free water held in large cavities(>50nm) begins escape to the environment.
 - In Fig2-12, thus a saturated hcp exposed to slightly less than 100RH can lose a considerable amount of water before undergoing any shrinkage.
-

Dimensional stability -2

- It should be pointed out here that the mechanisms which are responsible for drying shrinkage are also responsible for creep of the hcp.
 - In the case of creep, a sustained external stress becomes the driving force for **the movement of the physically adsorbed water**.
 - Thus **creep strain can occur even at 100% RH**.
-

Durability(permeability) 12·11

- The hcp is alkaline, therefore, **exposure to acidic water is detrimental.**
 - Under these conditions, impermeability also called water-tightness becomes a primary factor in determining durability.
 - **Strength and permeability** of the hcp are two sides of the same coin in the sense that **both are closely related to the capillary porosity or the solid/space ratio.**
 - In hcp a direct relationship was noted between **the permeability and the volume of pores larger than about 100nm.**
-

Transition zone in concrete

- Significance of the transition zone
 -
 - Have you ever wondered why?
 - * Concrete is brittle in tension but relatively tough in compression.
-

Significance of the transition zone

- * The composition of concrete when tested separately in a uniaxial compression remain elastic until failure, whereas concrete itself shows inelastic behavior
- * The compressive strength of a concrete is higher than its tensile strength by an order of magnitude
- etc,

The answer lie in the transition zone that exists between large particles of aggregate and the hcp.

Structure of the transition zone

- Finally, **poorly crystalline CSH** and a second generation of **smaller crystals of ettringite and calcium hydroxide** start filling the empty space that exists between the framework created by the large ettringite and calcium hydroxide crystals.
-

Strength of the transition zone

- In addition to the large volume of capillary voids and oriented calcium hydroxide crystals, a major factor responsible for the poor strength of the transition zone in concrete is the presence of microcracks.
 - The amount of microcracks depends on numerous parameters, including aggregate size and grading, cement content, water/cement ratio, degree of consolidation of fresh concrete, curing conditions, environmental humidity, and thermal history of concrete.
 - In other words, concrete has microcracks in the transition zone even before a structure is loaded.
-

Question

- それ自身で強度を低下させるひび割れはどのような形態なのですか？（長期的な鉄筋の腐食は考えないとして）
 - 引張応力に耐えられないひび割れ：無筋コンクリートでは非常に危ない。貫通ひび割れは曲げに耐えられない。ひび割れによる剥落で曲げに耐えられない。アルカリ骨材反応などでの微細ではあるが大量のひび割れは圧縮強度も低下させる。などなど
-

表-7(1) 施工要領と品質管理上のポイント(案)

ひび割れ部自動式低圧注入工法

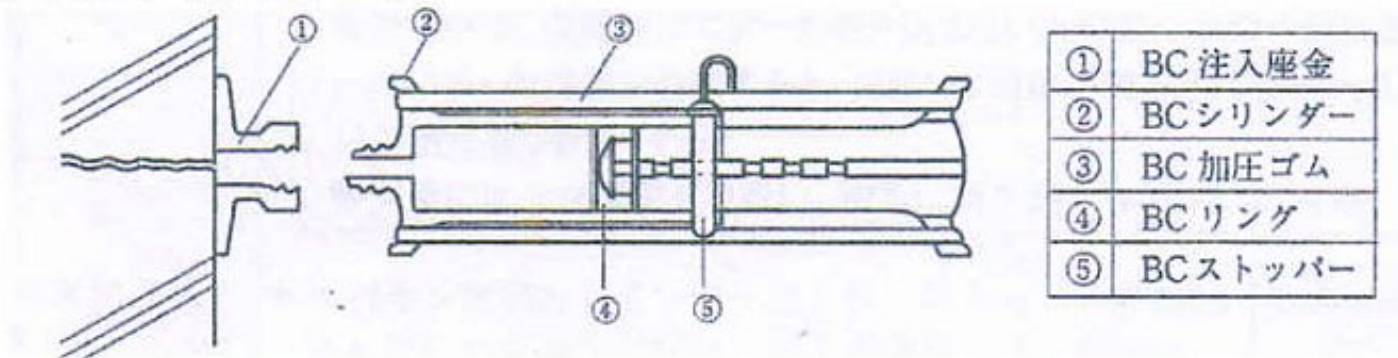

注入用台座取付

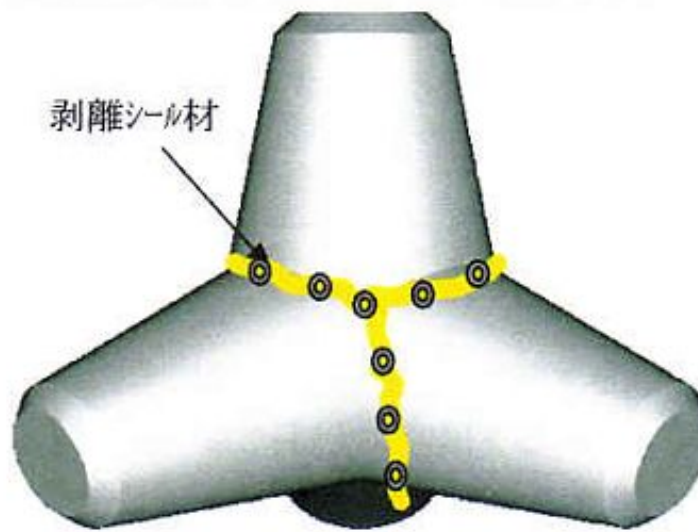

亀裂部シール

Influence of the transition zone on properties of concrete

- The transition zone, generally the weakest link of the chain, **is considered the strength-limiting phase in concrete.**
 - It is because the presence of the transition zone that concrete fails at a considerably lower stress level than the strength of either the two main components.
-

-
- Cracks in mortar
 - At stress levels higher than about 70% of the ultimate strength, the stress concentration at large voids in mortar matrix become large enough to initiate cracking there. (the stronger the concrete, the % will increase, fragile)
-

In the composite material, the transition zone serves as a bridge between the two components: the mortar matrix and the coarse aggregate.

Even when the individual components are of high stiffness, **the stiffness of components may be low because of the broken bridges.**

The rate of corrosion of steel is greatly influenced by the permeability of concrete. It should be noted that the permeation of air and water is necessary to corrosion of the steel in concrete. ITZ increases the permeability.

(The effect of the water/cement ratio on permeability and strength of concrete is generally attributed to the relationship that exists between **the water/cement ratio and the porosity of the hcp in concrete.**)

In general, everything remains the same, **the larger the aggregate and the higher the local water/cement ratio in the transition zone** and consequently, the weaker and more permeable will be the concrete.
